

Specification sheet

# XG+ Electric FT (4x2)

FT 4X2 Tractor, Electric



ENGINES
XG+ 270e EX-D2 (270kW)
XG+ 310e EX-D2 310kW)
XG+ 350e EX-D2 (350kW)

GVM <sup>1)</sup>	GCM <sup>2)</sup>
20500 kg	46000 kg
Max. front 7500 kg	
Max. rear 13000 kg	

991G0300ABAA - 202621F - 28-01-2026

DAF Trucks N.V., The Netherlands, [www.daf.com](http://www.daf.com)

## CAB EXTERIOR

Luxurious cab for XG+ series, with unrivalled aerodynamics for fuel efficient driving and low CO2 emissions. The huge and deep frontscreen, curved at the sides, and the large side windows offer an unsurpassed direct view for the driver, to enhance road safety. The cab interior is extremely comfortable for driving, living and sleeping with unprecedented spaciousness and practical layout. Cab length: 2690 mm; cab width: 2500 mm. Number of cab entrance steps: 3.; Cab suspension air; LED head, cornering and fog lights; Front view mirror.

### Optional

<b>02941</b> Chassis front execution: bottom plate	<b>01891</b> Hazard beacons on cab front, prepared
<b>02889</b> Chassis front execution: no bottom plate	<b>06629</b> Two hazard beacon lights
<b>03358</b> External sun visor	<b>03232</b> Front windscreen with solar control foil
<b>06790</b> Aluminium ladder 1-piece	<b>01550</b> No front view mirror
<b>06791</b> Aluminium ladder 2-piece	<b>01362</b> DAF Digital Vision System
<b>01015</b> LED Skylights; aux. LED lights on cab rf, prepared	<b>01913</b> DAF Corner View
<b>01925</b> Two LED work lamps for cab rear wall	

## AERODYNAMICS

### Optional

<b>01583</b> Adj. roof air deflector; over 4 m (!) for XG+ cab	<b>03074</b> Side collars, both sides hinged
<b>00052</b> Adjustable roof air deflector for XG+ cab	<b>03419</b> Side collars, extended. One side hinged
<b>04906</b> Side collars, one side hinged	<b>03076</b> Side collars, extended. Both sides hinged

## COLOURS

Cab colour E1980 Crystal White; Chassis colour grey.; Colour of bumper: Crystal White.

## CAB INTERIOR

Cab interior trim colour: Exclusive; Dashboard finish: Plateau; Cab interior decoration: Argenta; Driver seat: Luxury Air; Arm rest at both sides of the driver seat; Co-driver seat: cinema + table; fabric cover; Dashboard table; Storage compartment with drawer in centre; Upper bunk; Automatic Cab Climate Control; Auxiliary cab heater (water); Roof hatch, electric control.

### Optional

<b>02043</b> Dashboard finish: Vision	<b>02854</b> Xtra Comfort mattress for lower bunk
<b>02350</b> Cab interior decoration: Natura	<b>02858</b> Xtra Comfort mattress for adjustable lower bunk
<b>07736</b> Driver seat: Super Air	<b>01775</b> Xtra Comfort mattress with topper for lower bunk
<b>02241</b> Driver seat, swivel base	<b>02380</b> Mattress for DAF Relax Bed
<b>04050</b> Refrigerator and drawer	<b>04150</b> Mattress with topper for DAF Relax Bed
<b>04069</b> Two refrigerators	

## COMMUNICATION AND DRIVING MANAGEMENT

PACCAR Connect; Tachograph digital, Stoneridge version G2V2A; Speed limiter setting 85/90 km/h; Adaptive Cruise Control with FCW and AEBS-3; Driver Performance Assistant.

### Optional

<b>09681</b> Preparation for Maut	<b>06991</b> Predictive Cruise Control
<b>04553</b> Infotainment incl. DAF Truck Nav. and tablet prep.	<b>06992</b> Predictive Cruise Control lite
<b>03684</b> Infotainment including DAF Truck Navigation	

## SAFETY AND SECURITY

DAF drowsiness & distraction detection; Lane Departure Warning System; Vehicle Stability Control (VSC); Basic engine immobiliser system.

### Optional

<b>08631</b> Air bag (driver) and 2 seat belt tensioners	<b>01952</b> No DAF Side/Turn Assist
<b>02569</b> No Driver State Monitoring	

## SUSPENSION AND AXLES

Front: 8.00 t, parabolic, 163N; Rear axle load 13.00 t; Rear: air suspension, SR1344; No lifting device.

### Optional

<b>06257</b> Front axle load 9.00 t	<b>08191</b> Axle load monitoring
<b>04647</b> Front springs air	

## WHEELS AND TYRES

Driven rear axle(s): 315/70R22.5; F1,295/80R22.5GO FMAXS2 154/149 M Steering BCA; R1,315/70R22.5GO EQMD 154/150 L Traction BBB 3P.

### Optional

<b>16152</b> Tyre makes and types
-----------------------------------

## DRIVELINE

No engine.; Battery Electric Vehicle; Rear axle ratio 2.21; ASR.

### Optional

<b>02843</b> Mechanical differential lock
---

## BRAKE SYSTEM

### Optional

<b>04901</b> Spring brake cylinders on the first front axle
---

## CHASSIS

Wheelbase 3.90 m / rear overhang 0.99 m; Side member height 260 mm; Standard component location; Front underrun protection (FUP); Catwalk with step; Rear mudguards; Spray suppression; Work lamp LED.

### Optional

<b>16157</b> Fuel tanks, material and sizes	<b>03322</b> Rear light with bulbs
---	------------------------------------

## DRAWBAR AND TRAILER EQUIPMENT

JOST JSK42 cast iron 150+40mm; Pneumatic trailer connection palm type; Electric connection 24 V / 2x7 pins.

### Optional

<b>03178</b> Towing hook D= 4.3	<b>16151</b> 5th wheel makes and heights
<b>04359</b> Lead-up ramps	

## BODIES AND PREPARATIONS FOR BODYING

### Optional

**02811** Tail lift connection Anderson      **02812** Tail lift connection REMA

## 24V POWER SUPPLY

Batteries 2x 210 Ah AGM..

### Optional

**06440** Batteries 2x230Ah

## GVM AND GCM

Chassis weight related technical GVM max 20500 kg; Driveline related max GCM 46000 kg.

## SERVICE AND MAINTENANCE

Standard Warranty takes care of 1 year complete vehicle as supplied by the OEM (excl. real wear parts), 2nd year driveline and 1st year breakdown.; ITS service.

## VEHICLE DELIVERY

Minimum toolkit.

### Optional

**07569** Lifting jack

## OPTION PACKAGES

### Optional

**17448** Safety pack      **17596** Executive Pack XG/XG+

# XG+

## FT 4X2 Tractor, Electric

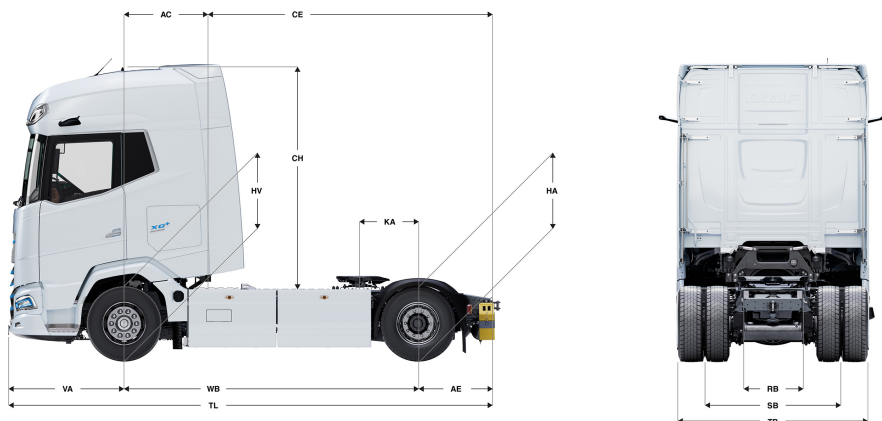

XG+ CAB	Wheelbase - AE <sup>5)</sup>		Unladen weight <sup>1)</sup>			Gross Carrying Capacity			Variable dimensions								
	WB	AE <sup>5)</sup>	Front	Rear	Total	Front	Rear	Total	AC	CE	CH <sup>6)</sup>	KA <sup>7)</sup>	TL	HA <sup>8)</sup>	HA <sup>9)</sup>	TK <sup>10)</sup>	TW <sup>11)</sup>
	3,90	0,99	6543	3597	10139	957	9403	10361	1,16	3,73	2,94	0,52	6,42	0,97	0,94	13,76	15,15

OTHER DIMENSIONS VA: 1,53 HV<sup>12)</sup>: 0,96 HV<sup>13)</sup>: 0,90 RB: 0,79 SB: 1,82 TB<sup>14)</sup>: 2,48

1) GVM in conformity with registration documents.  
 2) GCM in conformity with registration documents.  
 3) Axle load with standard tyre size.  
 4) Chassis and cab weight calculated with: Standard specification items only with 0 litres of fuel, 0 litres of AdBlue® and driver of 0 kg, tolerance ± 3%. Changing of the specification can have major impact on vehicle weight.  
 5) Other AE dimensions may be available for shown WB.  
 6) Cab height is measured from frame member to closed cabin roof hatch.  
 7) Calculate customer specific KA with TOPEC.

8) Unladen height at centre of driven axle(s).  
 9) Laden height at centre of driven axle(s).  
 10) TK = turning circle between kerbs.  
 11) TW = turning circle between walls.  
 12) Unladen height at centre of front axle(s).  
 13) Laden height at centre of front axle(s).  
 14) TB is overall width at rear. (At centre of front axle 255).

Depending on the vehicle configuration a specific option may not be possible. The availability and specification of this vehicle may differ per country. For further information please contact the DAF organisation. Pictures and technical illustrations are not binding in detail and can differ from the standard specification. Subject to modification without prior notice.