

Specification sheet

XG+ Electric FAW (8x4)

FAW 8X4 Rigid, Electric



ENGINES

XG+ 270e EX-D2 (270kW)
XG+ 310e EX-D2 (310kW)
XG+ 350e EX-D2 (350kW)

GVM¹⁾

32900 kg

Max. front 7500 kg

Max. rear 25400 kg

GCM²⁾

50000 kg

CAB EXTERIOR

Luxurious cab for XG+ series, with unrivalled aerodynamics for fuel efficient driving and low CO2 emissions. The huge and deep frontscreen, curved at the sides, and the large side windows offer an unsurpassed direct view for the driver, to enhance road safety. The cab interior is extremely comfortable for driving, living and sleeping with unprecedented spaciousness and practical layout. Cab length: 2690 mm; cab width: 2500 mm. Number of cab entrance steps: 3.; Cab suspension air; LED head, cornering and fog lights; Front view mirror.

Optional

- | | |
|---|---|
| 02941 Chassis front execution: bottom plate | 06629 Two hazard beacon lights |
| 02889 Chassis front execution: no bottom plate | 03232 Front windscreen with solar control foil |
| 03358 External sun visor | 01550 No front view mirror |
| 01015 LED Skylights; aux. LED lights on cab rf, prepared | 01362 DAF Digital Vision System |
| 01925 Two LED work lamps for cab rear wall | 01913 DAF Corner View |
| 01891 Hazard beacons on cab front, prepared | |

AERODYNAMICS

Optional

- | | |
|--|--|
| 01581 Adj. roof air deflector; over 4 m (l) for XG+ cab | 04906 Side collars, one side hinged |
| 00027 Adjustable roof air deflector for XG+ cab | 03074 Side collars, both sides hinged |

COLOURS

Cab colour E1980 Crystal White; Chassis colour grey.; Colour of bumper: Crystal White.

CAB INTERIOR

Cab interior trim colour: Exclusive; Dashboard finish: Plateau; Cab interior decoration: Argenta; Driver seat: Luxury Air; Arm rest at both sides of the driver seat; Co-driver seat: cinema + table; fabric cover; Dashboard table; Storage compartment with drawer in centre; Upper bunk; Automatic Cab Climate Control; Auxiliary cab heater (water); Roof hatch, electric control.

Optional

- | | |
|--|---|
| 02043 Dashboard finish: Vision | 04069 Two refrigerators |
| 02350 Cab interior decoration: Natura | 02854 Xtra Comfort mattress for lower bunk |
| 07736 Driver seat: Super Air | 02858 Xtra Comfort mattress for adjustable lower bunk |
| 07737 Driver seat: Xtra Leather Air | 01775 Xtra Comfort mattress with topper for lower bunk |
| 02241 Driver seat, swivel base | 02380 Mattress for DAF Relax Bed |
| 04050 Refrigerator and drawer | 04150 Mattress with topper for DAF Relax Bed |

COMMUNICATION AND DRIVING MANAGEMENT

PACCAR Connect; Tachograph digital, Stoneridge version G2V2A; Speed limiter setting 85/90 km/h; Adaptive Cruise Control with FCW and AEBS-3; Driver Performance Assistant.

Optional

- | | |
|---|---|
| 09681 Preparation for Maut | 09909 Adaptive Cruise Control (ACC) with FCW |
| 04553 Infotainment incl. DAF Truck Nav. and tablet prep. | 06991 Predictive Cruise Control |
| 09908 Cruise control | 06992 Predictive Cruise Control lite |

SAFETY AND SECURITY

DAF drowsiness & distraction detection; Lane Departure Warning System; Vehicle Stability Control (VSC); Basic engine immobiliser system.

Optional

- | | |
|--|--------------------------------------|
| 08631 Air bag (driver) and 2 seat belt tensioners | 01952 No DAF Side/Turn Assist |
| 02569 No Driver State Monitoring | |

SUSPENSION AND AXLES

Front: 8.00 t, parabolic, 163N; Rear axle load 10.50+10.50 t; Rear: 29.00 t, air suspension, SR1360T; Trailing axle load 8.0t; Lifting device.

Optional

- | | |
|--------------------------------------|-----------------------------------|
| 06257 Front axle load 9.00 t | 07494 Rear axle HR1670T |
| 06095 Front axle load 10.00 t | 08191 Axle load monitoring |

WHEELS AND TYRES

Driven rear axle(s): 295/80R22.5; F1,295/80R22.5GO FMAXS2 154/149 M Steering BCA; R1,295/80R22.5GO FMAXD2 152/148 M Traction CBA; R2,295/80R22.5GO FMAXS2 154/149 M Steering BCA.

Optional

- | |
|-----------------------------------|
| 16152 Tyre makes and types |
|-----------------------------------|

DRIVELINE

No engine.; Battery Electric Vehicle; Rear axle ratio 2.57.

BRAKE SYSTEM

Optional

- | |
|--|
| 00929 Driven rear axle with drum brakes |
|--|

CHASSIS

Wheelbase 5.00 m / rear overhang 2.05 m; Side member height 310 mm; Standard component location; Front underrun protection (FUP); Spray suppression.

Optional

- | | |
|---|------------------------------------|
| 16157 Fuel tanks, material and sizes | 03322 Rear light with bulbs |
|---|------------------------------------|

DRAWBAR AND TRAILER EQUIPMENT

D-value cross member D=13.7; Pneumatic trailer connection palm type; Electric connection 24 V / 2x7 pins.

Optional

- | | |
|--|----------------------------------|
| 07034 Trailer coupling Ringfeder D=20.0 B | 08908 No towing equipment |
| 08026 Trailer coupling Rockinger D=13.0 B | 06534 No EBS cable |
| 08027 Trailer coupling Rockinger D=20.0 B | |

BODIES AND PREPARATIONS FOR BODYING

Application connector chassis.

Optional

- | |
|--------------------------------------|
| 09421 Additional spare wiring |
|--------------------------------------|

24V POWER SUPPLY

Batteries 2x 210 Ah AGM..

Optional

06440 Batteries 2x230Ah

GVM AND GCM

Chassis weight related technical GVM max 37000 kg; Driveline related max GCM 50000 kg.

SERVICE AND MAINTENANCE

Standard Warranty takes care of 1 year complete vehicle as supplied by the OEM (excl. real wear parts), 2nd year driveline and 1st year breakdown.; ITS service.

VEHICLE DELIVERY

Minimum toolkit.

Optional

07569 Lifting jack

OPTION PACKAGES

Optional

17448 Safety pack

17596 Executive Pack XG/XG+

XG+

FAW 8X4 Rigid, Electric

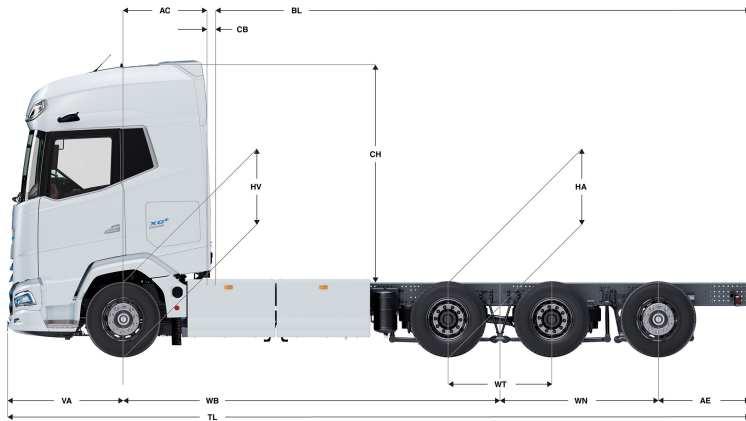

	Wheelbase - AE		Unladen weight ¹⁾			Gross Carrying Capacity			Variable dimensions									
	WB	AE ⁵⁾	Front	Rear	Total	Front	Rear	Total	AC	CB ⁶⁾	CH ⁷⁾	BL ⁸⁾	BL	TL	HA ⁹⁾	HA ¹⁰⁾	TK ¹¹⁾	TW ¹²⁾
XG+ CAB	4,05	1,20	6540	5493	12033	960	19907	20867	1,16	0,07	2,89	6,50	6,50	8,89	1,05	1,02	14,15	15,54
	4,30	2,05	6536	5604	12140	964	19796	20760	1,16	0,07	2,89	6,98	6,98	9,99	1,05	1,02	14,79	16,20
	4,55	2,05	6597	5566	12163	903	19834	20737	1,16	0,07	2,89	7,49	7,49	10,24	1,05	1,02	15,44	16,86
	5,00	2,05	7076	6163	13240	424	19237	19660	1,16	0,07	2,89	8,57	8,57	10,69	1,05	1,03	16,61	18,05
	5,55	2,05	7304	6122	13426	196	19278	19474	1,16	0,07	2,89	9,78	9,78	11,24	1,05	1,03	18,05	19,50

OTHER DIMENSIONS VA: 1,53 WT: 1,40 WN: 2,11 HV¹³⁾: 0,98 HV¹⁴⁾: 0,94 RB: 0,79 SB: 1,82 TB¹⁵⁾: 2,45

1) GVM in conformity with registration documents.
 2) GCM in conformity with registration documents.
 3) Axle load with standard tyre size.
 4) Chassis and cab weight calculated with: Standard specification items only with 0 litres of fuel, 0 litres of AdBlue® and driver of 0 kg, tolerance ± 3%. Changing of the specification can have major impact on vehicle weight.
 5) Other AE dimensions may be available for shown WB. Modify rear overhang to the calculated body length.
 6) CB is based on standard air intake and/or exhaust.
 7) Cab height is measured from frame member to closed cabin roof hatch.

8) Calculate customer specific body length with TOPEC. Body lengths shown based on evenly distributed load at max axle load.
 9) Unladen height at centre of driven axle(s).
 10) Laden height at centre of driven axle(s).
 11) TK = turning circle between kerbs.
 12) TW = turning circle between walls.
 13) Unladen height at centre of front axle(s).
 14) Laden height at centre of front axle(s).
 15) TB is overall width at rear. (At centre of front axle 255).

Depending on the vehicle configuration a specific option may not be possible. The availability and specification of this vehicle may differ per country. For further information please contact the DAF organisation. Pictures and technical illustrations are not binding in detail and can differ from the standard specification. Subject to modification without prior notice.