

Specification sheet

XB 230

FA 4X2 Rigid, 19t



ENGINES

XB NewGen 230 PX-7 (167 kW / 227 hp)
XB NewGen 260 PX-7 (189 kW / 257 hp)
XB NewGen 290 PX-7 (212 kW / 287 hp)
XB NewGen 310 PX-7 (227 kW / 308 hp)

GVM¹⁾

18500 kg
Max. front 7000 kg
Max. rear 11500 kg

GCM²⁾

19000 kg

CAB EXTERIOR

Day Cab with steel bumper, tinted glass and electric window openers. Main mirrors and wide angle mirrors electrically heated. Cab width 2130 mm.; Electrically adjustable mirrors; Mirror brackets, body 2.50-2.60 m; Front view mirror; Rear view camera.

Optional

02576 Extended Day Cab	02083 Two hazard beacon lights LED
02106 Sleeper Cab	
01605 Cab suspension mechanically reinforced	07343 Kerb view window co-driver door
09983 Fog lights	00915 Side no glass / rear single glass
09984 Fog lights and cornering lights	09101 Green tinted glass, heated
06629 Two hazard beacon lights	09283 Mirror brackets, body 2.40-2.50 m

AERODYNAMICS

Optional

09286 Roof air deflector prepared	07092 Adjustable roof air deflector low (set)
06776 Adjustable roof air deflector	09287 Side collars prepared
07109 Adjustable roof air deflector high (set)	07112 Side collars long (set)

COLOURS

; Head lamp panel and bumper: Stone Grey; Lower step cover, cab steps and wing Stone Grey.; Chassis colour grey..

Optional

06485 Head lamp panel and bumper: cab colour	00617 Lower step cover, cab steps and wing in cab colour
00733 Lower step cab colour, cab steps and wing Grey	16153 Cab and chassis colours

CAB INTERIOR

Left-hand drive (LHD); Mechanically adjustable steering column; Driver seat: air suspended; Co-driver seat: fixed velour; Storage box on engine tunnel.

Optional

01847 Right-hand drive (RHD)	04346 Lower bunk, normal level
09271 Steering wheel, leather, colour black	03703 Auxiliary cab heater Air Top 2000
03516 Pneumatically adjustable steering column	04246 Roof hatch, manual control
00967 Seat belts red	04258 Roof hatch, electric control
16158 Seat types	

COMMUNICATION AND DRIVING MANAGEMENT

FMS connector, prepared; Tachograph digital, Stoneridge 1C version G2V2; Driver Performance Assistant.

Optional

16155 Audio equipment, makes and types

SAFETY AND SECURITY

Speed limit recognition; DAF drowsiness detection; Drive-off Assist.

Optional

08631 Air bag (driver) and 2 seat belt tensioners	01723 No reverse warning
07414 Reverse warning with self-adjusting volume	16156 EC-ADR packages

SUSPENSION AND AXLES

Front axle type 152N, 100 mm vertical offset. Parabolic leaf suspension with shock absorbers and stabiliser. Max. load 7.5 tonnes.; Single reduction driven rear axle type SR1132 with parabolic leaf suspension, including shock absorbers and stabiliser. Max. load 11.5 tonnes..

Optional

04525 Rear: 11.50 t, asymmetric parabolic, SR1132	01372 Rear springs air
06870 Rear: 11.50 t, air suspension, SR1132	00369 Rear springs parabolic, asymmetric
03575 Rear: 13.00 t, air suspension, SR1344	01778 Rear axle load 13.00 t

WHEELS AND TYRES

Front axle(s): 295/80R22.5; Driven rear axle(s): 295/80R22.5; Goodyear; Wheel protection rings silvergrey.

Optional

06764 Wheel protection rings black	16152 Tyre makes and types
06766 Wheel protection rings chromium DAF	

DRIVELINE

Engine PX-7, 6 cylinder diesel engine, 6.7 litres. Output 167 kW (227 hp) at 1900 rpm. Max. torque 890 Nm at 1000-1700 rpm.; Exhaust emission Euro 6; Manual gearbox, 6 speeds; Gearbox ratio 6.75-0.78; Rear axle ratio 5.13.

Optional

04393 Manual gearbox, 9 speeds	02810 Rear axle ratio 4.11
07667 Automatic gearbox PowerLine, 8-speed	02808 Rear axle ratio 4.56
09888 Automatic gearbox, 5 speeds	00743 Rear axle ratio 4.63
02313 Gearbox direct drive	02813 Rear axle ratio 5.14
03702 Rear axle ratio 3.70	03431 Rear axle ratio 5.57
01879 Rear axle ratio 3.73	03315 Rear axle ratio 5.63
02800 Rear axle ratio 4.10	02843 Mechanical differential lock

BRAKE SYSTEM

Exhaust brake.

Optional

06195 Park brake control with test position	09525 Park brake ctl with test pos and spoken warning
09524 Park brake control with spoken warning	

CHASSIS

Wheelbase 3.75 m / rear overhang 1.63 m; Side member height 270 mm; EAS unit right, discharge right rearward; Battery box left, no spare wheel carrier; Plastic fuel tank 200 l; Tank for AdBlue® 30 l, right-hand side chassis; Front underrun protection (FUP); Spray suppression.

Optional

04439 Battery box left, spare wheel carrier right	07071 Spare wheel carrier right-hand side
01623 Rear underrun protection	03323 Rear light with LEDs

DRAWBAR AND TRAILER EQUIPMENT

Closing member D-value = 0kN.

Optional

- | | |
|--|--|
| 06779 Cross member D85-Dc70 -V25, no coupling, mounted | 04638 Trailer coupling D= 8.5 |
| 01433 Cross member D100-Dc70-V25, no coupling, mounted | 07034 Trailer coupling Ringfeder D=20.0 |
| 03417 Cross member D137-Dc92-V40, no coupling, mounted | 04661 D-value cross member D= 8.5 |
| 06657 Cross member D85-Dc70 -V25, coupling D85, mounted | 01948 D-value cross member D=10 |
| 02639 Cross member D137 + Ringfeder cplg D200, mounted | 07029 D-value cross member D=13.7 |

BODIES AND PREPARATIONS FOR BODYING

Application connector chassis; Standard body attachment hole pattern.

Optional

- | | |
|---|---|
| 06691 Application connector on the cab front | 01502 No side marker lights |
| 02950 Application connector for hydraulic platform | 07487 Body attachment BAM 1, loose consoles supply |
| 09240 Application connector for refuse collector | 07488 Body attachment BAM 3, loose consoles supply |

POWER TAKE-OFF (PTO)

Optional

- | | |
|--|--|
| 00590 Front engine PTO with generator preparation 17 kW | 01250 Front engine PTO with generator preparation 30 kW |
| 06785 Front engine PTO, generator preparation 22.5 kW | 06282 Rear eng PTO 13h, permanent, pump drive |
| 00591 Front engine PTO with generator preparation 24 kW | 16148 PTO types and positions |

24V POWER SUPPLY

Alternator 100 A, batteries 2x 175 Ah..

Optional

- | | |
|------------------------------|--------------------------------|
| 02544 Alternator 80 A | 01906 Batteries 2x125Ah |
|------------------------------|--------------------------------|

GVM AND GCM

Chassis weight related technical GVM max 19000 kg; Driveline related technical GCM equal to GVM.

Optional

- | | |
|---|---|
| 00064 Driveline related max GCM 22500 kg | 00620 Driveline related max GCM 28000 kg |
| 02658 Driveline related max GCM 26000 kg | 03027 Driveline related max GCM 32000 kg class 3 |

APPLICATION CONDITIONS

Moisture separator, unheated; Air intake low.

Optional

- | | |
|---|---|
| 02270 Cold climate | 04482 Air intake high behind cab |
| 04767 Moisture separator, heated | 09960 Air intake on the cab roof |

VEHICLE DELIVERY

Standard toolkit.

Optional

- | |
|-------------------------------------|
| 06491 Toolkit Eastern Europe |
|-------------------------------------|

Go to [DAF.com](https://www.daf.com) to configure your own perfect DAF.

XB 230

FA 4X2 Rigid, 19t

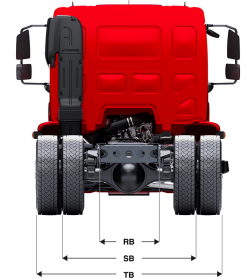
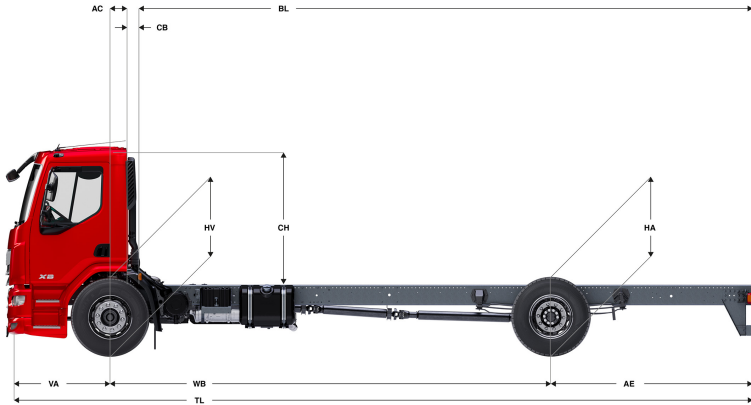

	Wheelbase - AE		Unladen weight ⁹⁾			Gross Carrying Capacity			Variable dimensions									
	WB	AE ⁹⁾	Front	Rear	Total	Front	Rear	Total	AC	CB ⁸⁾	CH ⁷⁾	BL ⁸⁾	BL	TL	HA ⁹⁾	HA ¹⁰⁾	TK ¹¹⁾	TW ¹²⁾
DAY CAB	3,45	1,48	3272	1610	4882	3728	9890	13618	0,23	0,12	1,88	4,14	4,14	6,32	1,05	0,84	12,96	14,09
	3,75	1,63	3313	1651	4964	3687	9849	13536	0,23	0,12	1,88	4,57	4,57	6,76	1,04	0,84	13,77	14,92
	4,15	1,83	3318	1675	4993	3682	9825	13507	0,23	0,12	1,88	5,12	5,12	7,36	1,04	0,84	14,86	16,03
	4,45	1,98	3329	1702	5031	3671	9798	13469	0,23	0,12	1,88	5,55	5,55	7,81	1,04	0,84	15,69	16,86
	4,75	2,13	3334	1720	5054	3666	9780	13446	0,23	0,12	1,88	5,97	5,97	8,26	1,04	0,84	16,51	17,69
	5,00	2,25	3348	1745	5093	3652	9755	13407	0,23	0,12	1,88	6,31	6,31	8,64	1,04	0,84	17,19	18,39
	5,30	2,40	3353	1762	5115	3647	9738	13385	0,23	0,12	1,88	6,74	6,74	9,09	1,04	0,84	18,02	19,22
	5,85	2,68	3390	1838	5228	3610	9662	13272	0,23	0,12	1,88	7,51	7,51	9,91	1,04	0,84	19,53	20,75
	6,25	2,88	3398	1864	5262	3602	9636	13238	0,23	0,12	1,88	8,06	8,06	10,51	1,04	0,84	20,63	21,86
6,60	2,85	3422	1880	5301	3578	9620	13199	0,23	0,12	1,88	8,58	8,58	10,84	1,04	0,84	21,60	22,83	
6,90	3,00	3441	1920	5361	3559	9580	13139	0,23	0,12	1,88	9,01	9,01	11,29	1,04	0,84	22,43	23,66	
SLEEPER CAB	3,45	1,48	3414	1592	5007	3586	9908	13493	0,63	0,07	1,88	3,49	3,49	6,32	1,05	0,84	12,96	14,09
	3,75	1,63	3453	1635	5088	3547	9865	13412	0,63	0,07	1,88	3,92	3,92	6,76	1,04	0,84	13,77	14,92
	4,15	1,83	3457	1661	5118	3543	9839	13382	0,63	0,07	1,88	4,49	4,49	7,36	1,04	0,84	14,86	16,03
	4,45	1,98	3467	1689	5156	3533	9811	13344	0,63	0,07	1,88	4,91	4,91	7,81	1,04	0,84	15,69	16,86
	4,75	2,13	3471	1708	5178	3529	9792	13322	0,63	0,07	1,88	5,33	5,33	8,26	1,04	0,84	16,51	17,69
	5,00	2,25	3484	1733	5218	3516	9767	13282	0,63	0,07	1,88	5,69	5,69	8,64	1,04	0,84	17,19	18,39
	5,30	2,40	3488	1751	5239	3512	9749	13261	0,63	0,07	1,88	6,11	6,11	9,09	1,04	0,84	18,02	19,22
	5,85	2,68	3524	1828	5353	3476	9672	13147	0,63	0,07	1,88	6,89	6,89	9,91	1,04	0,84	19,53	20,75
	6,25	2,88	3532	1855	5386	3468	9645	13114	0,63	0,07	1,88	7,46	7,46	10,51	1,04	0,84	20,63	21,86
6,60	2,85	3555	1871	5426	3445	9629	13074	0,63	0,07	1,88	7,97	7,97	10,84	1,04	0,84	21,60	22,83	
6,90	3,00	3574	1912	5486	3426	9588	13014	0,63	0,07	1,88	8,40	8,40	11,29	1,04	0,84	22,43	23,66	

OTHER DIMENSIONS	VA: 1,39	HV ¹³⁾ : 1,00	HV ¹⁴⁾ : 0,92	RB: 0,79	SB: 1,82	TB ¹⁵⁾ : 2,45
------------------	----------	--------------------------	--------------------------	----------	----------	--------------------------

- GVM in conformity with registration documents.
- GCM in conformity with registration documents.
- Axle load with standard tyre size.
- Chassis and cab weight calculated with: Standard specification items only with 0 litres of fuel, 0 litres of AdBlue® and driver of 75 kg, tolerance ± 3%. Changing of the specification can have major impact on vehicle weight.
- Other AE dimensions may be available for shown WB. Modify rear overhang to the calculated body length.
- CB is based on standard air intake and/or exhaust.
- Cab height is measured from frame member to closed cabin roof hatch.
- Calculate customer specific body length with TOPEC. Body lengths shown based on evenly distributed load at max axle load.
- Unladen height at centre of driven axle(s).
- Laden height at centre of driven axle(s).
- TK = turning circle between kerbs.
- TW = turning circle between walls.
- Unladen height at centre of front axle(s).
- Laden height at centre of front axle(s).
- TB is overall width at rear. (At centre of front axle 255).

Depending on the vehicle configuration a specific option may not be possible. The availability and specification of this vehicle may differ per country. For further information please contact the DAF organisation. Pictures and technical illustrations are not binding in detail and can differ from the standard specification. Subject to modification without prior notice.