

Specification sheet

XB 190

FA 4X2 Rigid, 10t

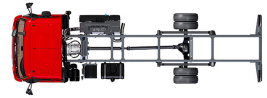

ENGINES

XB NewGen 190 PX-5 (139 kW / 189 hp)
XB NewGen 210 PX-5 (153 kW / 208 hp)
XB NewGen 230 PX-7 (167 kW / 227 hp)
XB NewGen 260 PX-7 (189 kW / 257 hp)

GVM¹⁾

10000 kg
Max. front 4000 kg
Max. rear 7200 kg

GCM²⁾

10000 kg

CAB EXTERIOR

Day Cab with steel bumper, tinted glass and electric window openers. Main mirrors and wide angle mirrors electrically heated. Cab width 2130 mm.; Electrically adjustable mirrors; Mirror brackets, body 2.50-2.60 m; Front view mirror; Rear view camera.

Optional

02576 Extended Day Cab	02083 Two hazard beacon lights LED
02106 Sleeper Cab	07343 Kerb view window co-driver door
01173 Cab suspension mechanical	00915 Side no glass / rear single glass
01605 Cab suspension mechanical reinforced	09101 Green tinted glass, heated
09983 Fog lights	03605 Mirror brackets, body 2.10-2.29 m
09984 Fog lights and cornering lights	09282 Mirror brackets, body 2.30-2.40 m
06629 Two hazard beacon lights	09283 Mirror brackets, body 2.40-2.50 m

AERODYNAMICS

Optional

09286 Roof air deflector prepared	07092 Adjustable roof air deflector low (set)
06776 Adjustable roof air deflector	09287 Side collars prepared
07109 Adjustable roof air deflector high (set)	07112 Side collars long (set)

COLOURS

; Head lamp panel and bumper: Stone Grey; Cab steps and wing Stone Grey; Chassis colour grey..

Optional

06485 Head lamp panel and bumper: cab colour	16153 Cab and chassis colours
01109 Cab steps and wing in cab colour	

CAB INTERIOR

Left-hand drive (LHD); Mechanically adjustable steering column; Driver seat: air suspended; Co-driver seat: fixed velour; Storage box on engine tunnel.

Optional

01847 Right-hand drive (RHD)	04346 Lower bunk, normal level
09271 Steering wheel, leather, colour black	03703 Auxiliary cab heater Air Top 2000
03516 Pneumatically adjustable steering column	04246 Roof hatch, manual control
00967 Seat belts red	04258 Roof hatch, electric control
16158 Seat types	

COMMUNICATION AND DRIVING MANAGEMENT

FMS connector, prepared; Tachograph digital, Stoneridge 1C version G2V2; Driver Performance Assistant.

Optional

16155 Audio equipment, makes and types

SAFETY AND SECURITY

Speed limit recognition; DAF drowsiness detection; Drive-off Assist.

Optional

08631 Air bag (driver) and 2 seat belt tensioners	01723 No reverse warning
07414 Reverse warning with self-adjusting volume	16156 EC-ADR packages

SUSPENSION AND AXLES

Front axle type 45N. Parabolic leaf suspension with shock absorbers and stabiliser. Max. load 4.0 tonnes.; Single reduction driven rear axle type SR8.14 with parabolic leaf suspension, including shock absorbers and stabiliser. Max. load 7.20 tonnes..

Optional

00823 Rear: 7.20 t, asymmetric parabolic, SR8.14	01372 Rear springs air
00871 Rear: 7.20 t, air suspension, SR8.14	00369 Rear springs parabolic, asymmetric

WHEELS AND TYRES

Front axle(s): 245/70R17.5; Driven rear axle(s): 245/70R17.5; Goodyear; Wheel protection rings silvergrey.

Optional

06764 Wheel protection rings black	16152 Tyre makes and types
-------------------------------------------	-----------------------------------

DRIVELINE

Engine PX-5, 4 cylinder diesel engine, 4.5 litres. Output 139 kW (189 hp) at 2300 rpm. Max. torque 745 Nm at 1200-1700 rpm.; Exhaust emission Euro 6; Manual gearbox, 6 speeds; Gearbox ratio 6.58-0.78; Rear axle ratio 3.31.

Optional

07667 Automatic gearbox PowerLine, 8-speed	02808 Rear axle ratio 4.56
09888 Automatic gearbox, 5 speeds	03042 Rear axle ratio 4.88
01879 Rear axle ratio 3.73	02843 Mechanical differential lock
02800 Rear axle ratio 4.10	

BRAKE SYSTEM

Exhaust brake.

Optional

06195 Park brake control with test position	09525 Park brake ctl with test pos and spoken warning
09524 Park brake control with spoken warning	

CHASSIS

Wheelbase 3.55 m / rear overhang 1.98 m; Side member height 210 mm; EAS unit right, discharge right rearward; Battery box left, no spare wheel carrier; Plastic fuel tank 110 l; Tank for AdBlue® 30 l, right-hand side chassis; Spray suppression.

Optional

04426 Batteries left, spare wheel carrier in re overhang	02011 Spare wheel carrier in rear overhang
04439 Battery box left, spare wheel carrier right	07071 Spare wheel carrier right-hand side
01623 Rear underrun protection	03323 Rear light with LEDs

DRAWBAR AND TRAILER EQUIPMENT

Closing member D-value = 0kN.

Optional

- 06779** Cross member D85-Dc70 **04661** D-value cross member D=-V25, no coupling, mounted
- 06657** Cross member D85-Dc70 -V25, coupling D85, mounted

BODIES AND PREPARATIONS FOR BODYING

Application connector chassis; Standard body attachment hole pattern.

Optional

- 02950** Application connector for hydraulic platform **07487** Body attachment BAM 1, loose consoles supply
- 09240** Application connector for refuse collector **07488** Body attachment BAM 3, loose consoles supply
- 01502** No side marker lights

POWER TAKE-OFF (PTO)

Optional

- 06624** Indirect front engine PTO **06282** Rear eng PTO 13h, permanent, pump drive
- 06785** Front engine PTO, generator preparation **16148** PTO types and positions 22.5 kW

24V POWER SUPPLY

Alternator 100 A, batteries 2x 175 Ah..

Optional

- 02544** Alternator 80 A **01906** Batteries 2x125Ah

GVM AND GCM

Chassis weight related technical GVM max 10000 kg; Driveline related technical GCM equal to GVM.

Optional

- 00728** Driveline related max GCM 20000 kg **03700** Driveline related technical GCM = GVM+3500 kg

APPLICATION CONDITIONS

Moisture separator, unheated; Air intake low.

Optional

- 02270** Cold climate **04482** Air intake high behind cab
- 04767** Moisture separator, heated **09960** Air intake on the cab roof

VEHICLE DELIVERY

Standard toolkit.

Optional

- 06491** Toolkit Eastern Europe

XB 190

FA 4X2 Rigid, 10t

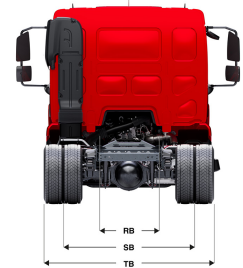
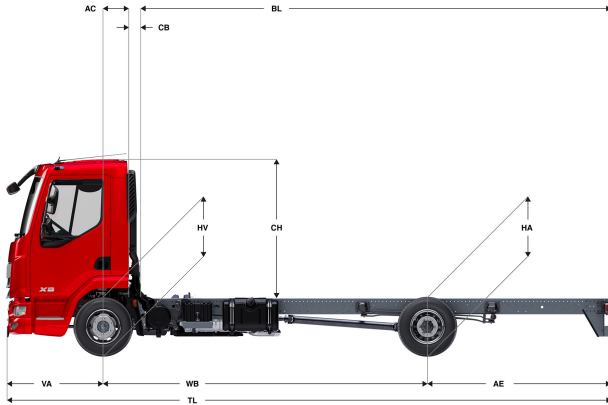

	Wheelbase - AE		Unladen weight ¹⁾			Gross Carrying Capacity			Variable dimensions									
	WB	AE ⁵⁾	Front	Rear	Total	Front	Rear	Total	AC	CB ⁶⁾	CH ⁷⁾	BL ⁸⁾	BL	TL	HA ⁹⁾	HA ¹⁰⁾	TK ¹¹⁾	TW ¹²⁾
DAY CAB	3,15	1,73	2537	1055	3592	1463	6145	6408	0,33	0,12	1,84	3,96	5,14	6,17	0,98	0,97	10,74	12,06
	3,55	1,98	2563	1090	3653	1437	6110	6347	0,33	0,12	1,84	4,60	5,93	6,82	0,98	0,97	11,71	13,05
	3,90	2,23	2566	1109	3675	1434	6091	6326	0,33	0,12	1,84	5,14	6,61	7,42	0,97	0,97	12,57	13,92
	4,30	2,43	2575	1131	3706	1425	6069	6294	0,33	0,12	1,84	5,76	7,38	8,02	0,97	0,98	13,55	14,92
	4,65	2,75	2576	1154	3730	1424	6046	6270	0,33	0,12	1,84	6,29	8,06	8,69	0,97	0,97	14,41	15,79
	5,00	2,83	2591	1170	3761	1409	6030	6239	0,33	0,12	1,84	6,86	8,76	9,12	0,97	0,98	15,27	16,66
	5,40	2,43	2617	1158	3775	1383	6042	6225	0,33	0,12	1,84	7,51	9,57	9,12	1,00	1,00	16,26	17,66
	5,70	2,41	2631	1167	3798	1369	6033	6203	0,33	0,12	1,84	7,99	10,18	9,40	0,97	1,00	17,00	18,41
	6,10	2,65	2637	1187	3825	1363	6013	6176	0,33	0,12	1,84	8,62	10,97	10,04	0,97	1,00	17,99	19,41
6,40	2,80	2645	1205	3851	1355	5995	6150	0,33	0,12	1,84	9,09	11,56	10,49	0,97	1,00	18,73	20,16	
6,70	3,00	2652	1226	3878	1348	5974	6122	0,33	0,12	1,84	9,56	12,17	10,99	0,97	1,00	19,48	20,91	
SLEEPER CAB	3,55	1,98	2705	1072	3777	1295	6128	6223	0,73	0,07	1,87	4,02	5,39	6,82	0,98	0,96	11,71	13,05
	3,90	2,23	2706	1093	3799	1294	6107	6202	0,73	0,07	1,87	4,58	6,07	7,42	0,98	0,96	12,57	13,92
	4,30	2,43	2713	1117	3830	1287	6083	6170	0,73	0,07	1,87	5,21	6,87	8,02	0,97	0,97	13,55	14,92
	4,65	2,75	2713	1141	3854	1287	6059	6146	0,73	0,07	1,87	5,76	7,56	8,69	0,97	0,97	14,41	15,79
	5,00	2,83	2728	1158	3885	1272	6042	6115	0,73	0,07	1,87	6,33	8,28	9,12	0,97	0,97	15,27	16,66
	5,40	2,43	2752	1146	3899	1248	6054	6101	0,73	0,07	1,87	6,99	9,11	9,12	0,97	0,99	16,26	17,66
	5,70	2,41	2766	1156	3922	1234	6044	6079	0,73	0,07	1,87	7,49	9,73	9,40	0,97	1,00	17,00	18,41
	6,10	2,65	2772	1177	3949	1228	6023	6052	0,73	0,07	1,87	8,13	10,54	10,04	0,97	1,00	17,99	19,41
	6,40	2,80	2779	1196	3975	1221	6004	6026	0,73	0,07	1,87	8,61	11,15	10,49	0,97	1,00	18,73	20,16
6,70	3,00	2785	1217	4002	1215	5983	5998	0,73	0,07	1,87	9,09	11,76	10,99	0,97	1,00	19,48	20,91	

OTHER DIMENSIONS	VA: 1,29	HV ¹³⁾ : 0,92	HV ¹⁴⁾ : 0,87	RB: 0,86	SB: 1,75	TB ¹⁵⁾ : 2,33
------------------	----------	--------------------------	--------------------------	----------	----------	--------------------------

1) GVM in conformity with registration documents.
 2) GCM in conformity with registration documents.
 3) Axle load with standard tyre size.
 4) Chassis and cab weight calculated with: Standard specification items only with 0 litres of fuel, 0 litres of AdBlue® and driver of 75 kg, tolerance ± 3%. Changing of the specification can have major impact on vehicle weight.
 5) Other AE dimensions may be available for shown WB. Modify rear overhang to the calculated body length.
 6) CB is based on standard air intake and/or exhaust.
 7) Cab height is measured from frame member to closed cabin roof hatch.

8) Calculate customer specific body length with TOPEC. Body lengths shown based on evenly distributed load at max axle load.
 9) Unladen height at centre of driven axle(s).
 10) Laden height at centre of driven axle(s).
 11) TK = turning circle between kerbs.
 12) TW = turning circle between walls.
 13) Unladen height at centre of front axle(s).
 14) Laden height at centre of front axle(s).
 15) TB is overall width at rear. (At centre of front axle 255).

Depending on the vehicle configuration a specific option may not be possible. The availability and specification of this vehicle may differ per country. For further information please contact the DAF organisation. Pictures and technical illustrations are not binding in detail and can differ from the standard specification. Subject to modification without prior notice.