

# Specification sheet

# XB 120

FA 4X2 Rigid, 12t Electric ChsBody

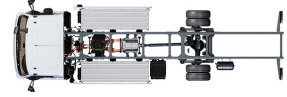

## ENGINES

XB Electric 12t PACCAR EX-M1 (120 kW / 141 kWh | 210/282 kWh)

## GVM<sup>1)</sup>

12000 kg

## GCM<sup>2)</sup>

12000 kg

Max. front 4480 kg

Max. rear 8480 kg

## CAB EXTERIOR

Day Cab with steel bumper, tinted glass and electric window openers. Main mirrors and wide angle mirrors electrically heated. Cab width 2130 mm.; Electrically adjustable mirrors; Mirror brackets, body 2.50-2.60 m; Front view mirror; Rear view camera.

### Optional

<b>02576</b> Extended Day Cab	<b>02083</b> Two hazard beacon lights LED
<b>03175</b> Cab suspension rubber and mechanical	<b>07343</b> Kerb view window co-driver door
<b>01605</b> Cab suspension mechanical reinforced	<b>00915</b> Side no glass / rear single glass
<b>09983</b> Fog lights	<b>09101</b> Green tinted glass, heated
<b>09984</b> Fog lights and cornering lights	<b>09283</b> Mirror brackets, body 2.40-2.50 m
<b>06629</b> Two hazard beacon lights	

## AERODYNAMICS

### Optional

<b>09286</b> Roof air deflector prepared	<b>07092</b> Adjustable roof air deflector low (set)
<b>06776</b> Adjustable roof air deflector	<b>09287</b> Side collars prepared
<b>07109</b> Adjustable roof air deflector high (set)	<b>07112</b> Side collars long (set)

## COLOURS

; Head lamp panel and bumper: Stone Grey; Cab steps and wing Stone Grey; Chassis colour grey..

### Optional

<b>06485</b> Head lamp panel and bumper: cab colour	<b>01303</b> Curtain colour 557 blue, panels white
<b>01109</b> Cab steps and wing in cab colour	<b>01340</b> Curtain colour 602 green, panels white
<b>04674</b> Body panels standard white	<b>01344</b> Curtain colour 763 grey, panels white
<b>01238</b> Curtain colour 907 white, panels white	<b>01350</b> Curtain colour 905 black, panels white
<b>01241</b> Curtain colour 148 yellow, panels white	<b>16153</b> Cab and chassis colours
<b>01298</b> Curtain colour 356 red, panels white	

## CAB INTERIOR

Left-hand drive (LHD); Mechanically adjustable steering column; Driver seat: air suspended; Co-driver seat: fixed velour; Storage box on engine tunnel.

### Optional

<b>01847</b> Right-hand drive (RHD)	<b>16158</b> Seat types
<b>09271</b> Steering wheel, leather, colour black	<b>04246</b> Roof hatch, manual control
<b>03516</b> Pneumatically adjustable steering column	<b>04258</b> Roof hatch, electric control
<b>00967</b> Seat belts red	

## COMMUNICATION AND DRIVING MANAGEMENT

FMS connector, prepared; Tachograph digital, Stoneridge 1C version G2V2; Driver Performance Assistant.

### Optional

<b>16155</b> Audio equipment, makes and types
---

## SAFETY AND SECURITY

Speed limit recognition; DAF drowsiness detection; Drive-off Assist.

### Optional

<b>08631</b> Air bag (driver) and 2 seat belt tensioners	<b>01723</b> No reverse warning
<b>07414</b> Reverse warning with self-adjusting volume	

## SUSPENSION AND AXLES

Front axle type 45N. Parabolic leaf suspension with shock absorbers and stabiliser. Max. load 4.5 tonnes.; Single reduction driven rear axle type SR8.14 with parabolic leaf suspension, including shock absorbers and stabiliser. Max. load 8.50 tonnes..

### Optional

<b>00988</b> Rear: 8.50 t, air suspension, SR8.14	<b>01372</b> Rear springs air suspension, SR8.14
---	--

## WHEELS AND TYRES

Front axle(s): 245/70R17.5; Driven rear axle(s): 245/70R17.5; Goodyear; Wheel protection rings silvergrey.

### Optional

<b>06764</b> Wheel protection rings black	<b>16152</b> Tyre makes and types black
---	---

## DRIVELINE

Electric motor type EX-M1; 120 kW; Battery Electric Vehicle; Rear axle ratio 4.88.

## BRAKE SYSTEM

### Optional

<b>09524</b> Park brake control with spoken warning
---

## CHASSIS

Wheelbase 4.65 m / rear overhang 2.75 m; Side member height 210 mm; Battery box LH rear, no spare wheel carrier; Battery pack C-type; 2 HV battery packs: L1+R1, C-type; 2 HV battery packs; Spray suppression.

### Optional

<b>04189</b> Battery pack H-type	<b>04177</b> 1 HV battery pack
<b>00725</b> 1 HV battery pack: L1, H-type	<b>01623</b> Rear underrun protection
<b>00703</b> 1 HV battery pack: R1, H-type	<b>03323</b> Rear light with LEDs
<b>00686</b> 2 HV battery packs: L1+R1, H-type	

## DRAWBAR AND TRAILER EQUIPMENT

Closing member D-value = 0kN.

## BODIES AND PREPARATIONS FOR BODYING

Standard body attachment hole pattern.

### Optional

<b>00126</b> Body attachment BAM 1, consoles type B	<b>02717</b> Aluminium kick strips, front and sides 228 mm
<b>02357</b> Box body	<b>02712</b> Aluminium kick strips, front 228 mm
<b>01890</b> Curtain sider body	<b>02727</b> Galvanised kick strips, front and sides 200 mm
<b>03562</b> Aerobody	<b>02728</b> Plywood kick strips, front and sides 300 mm
<b>02622</b> External body length 6100 mm	<b>02738</b> Plywood kick strips, front 1200 mm, sides 300 mm
<b>02650</b> External body length 6810 mm	<b>04650</b> Rear wide lath shutter door
<b>06463</b> External body length 7100 mm	<b>04662</b> Rear double doors
<b>04619</b> External body width 2480 mm	<b>02726</b> Single, hinged side door at front left-hand side
<b>04621</b> External body width 2540 mm	<b>04297</b> Single, hinged side door at rear right-hand side
<b>01403</b> GRP faced plywood panels	<b>02718</b> Side roller shutter door
<b>00067</b> Contour markings	<b>04637</b> Column tail lift
<b>02702</b> Standard body floor	<b>04640</b> Tuck-under tail lift
<b>02698</b> Body floor with 3 mm aluminium tread plate	<b>06464</b> Tail lift 1.5 tonnes

### 24V POWER SUPPLY

Batteries 2x 140 Ah..

#### Optional

**08797** Batteries 2x175Ah

### GVM AND GCM

Chassis weight related technical GVM max 12000 kg; Driveline related technical GCM equal to GVM.

### APPLICATION CONDITIONS

#### Optional

**01282** Moderate climate

### VEHICLE DELIVERY

Standard toolkit.

#### Optional

**06491** Toolkit Eastern Europe

Go to [DAF.com](https://www.daf.com) to configure your own perfect DAF.

# XB 120

## FA 4X2 Rigid, 12t Electric ChsBody

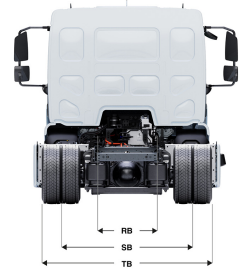
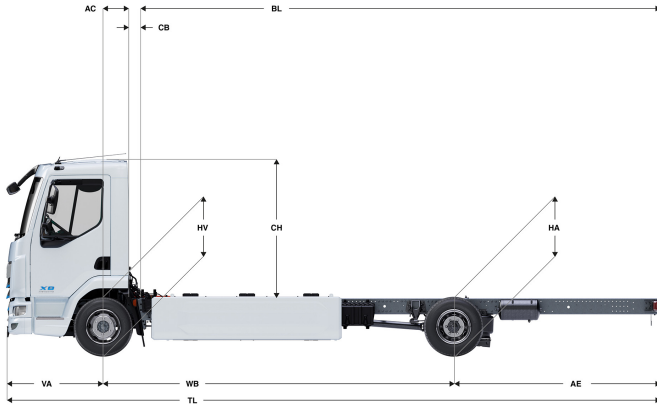

	Wheelbase - AE		Unladen weight <sup>1)</sup>			Gross Carrying Capacity			Variable dimensions									
	WB	AE <sup>5)</sup>	Front	Rear	Total	Front	Rear	Total	AC	CB <sup>6)</sup>	CH <sup>7)</sup>	BL <sup>8)</sup>	BL	TL	HA <sup>9)</sup>	HA <sup>10)</sup>	TK <sup>11)</sup>	TW <sup>12)</sup>
DAY CAB	4,30	2,43	3116	2224	5340	1364	6256	6660	0,33	0,23	1,87	5,69	6,98	8,02	0,94	0,91	13,82	14,92
	4,65	2,75	3219	2093	5313	1261	6387	6688	0,33	0,23	1,87	6,41	7,78	8,69	0,97	0,87	14,68	15,79
	5,00	2,46	3311	2022	5333	1169	6458	6667	0,33	0,23	1,87	7,10	8,59	8,75	0,97	0,89	15,54	16,66

OTHER DIMENSIONS	VA: 1,29	HV <sup>13)</sup> : 0,89	HV <sup>14)</sup> : 0,88	RB: 0,86	SB: 1,75	TB <sup>15)</sup> : 2,33
------------------	----------	--------------------------	--------------------------	----------	----------	--------------------------

1) GVM in conformity with registration documents.  
 2) GCM in conformity with registration documents.  
 3) Axle load with standard tyre size.  
 4) Chassis and cab weight calculated with: Standard specification items only with 0 litres of fuel, 0 litres of AdBlue® and driver of 75 kg, tolerance ± 3%. Changing of the specification can have major impact on vehicle weight.  
 5) Other AE dimensions may be available for shown WB. Modify rear overhang to the calculated body length.  
 6) CB is based on standard air intake and/or exhaust.  
 7) Cab height is measured from frame member to closed cabin roof hatch.

8) Calculate customer specific body length with TOPEC. Body lengths shown based on evenly distributed load at max axle load.  
 9) Unladen height at centre of driven axle(s).  
 10) Laden height at centre of driven axle(s).  
 11) TK = turning circle between kerbs.  
 12) TW = turning circle between walls.  
 13) Unladen height at centre of front axle(s).  
 14) Laden height at centre of front axle(s).  
 15) TB is overall width at rear. (At centre of front axle 255).

Depending on the vehicle configuration a specific option may not be possible. The availability and specification of this vehicle may differ per country. For further information please contact the DAF organisation. Pictures and technical illustrations are not binding in detail and can differ from the standard specification. Subject to modification without prior notice.