

Specification sheet

LF 190

FA 4X2 Rigid, 12t

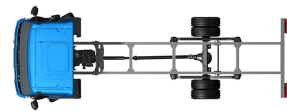

ENGINES

- LF 190 PX-5 (139 kW / 189 hp)
- LF 210 PX-5 (153 kW / 208 hp)
- LF 230 PX-7 (167 kW / 227 hp)
- LF 260 PX-7 (189 kW / 257 hp)

GVM¹⁾

- 12000 kg
- Max. front 4480 kg
- Max. rear 8480 kg

GCM²⁾

- 12000 kg

067F3602BBAA - 202345C - 21-08-2023

Greece, ERGOTRAK, www.daftrucks.gr

CAB EXTERIOR

Day Cab with steel bumper, tinted glass and electric window openers. Main mirrors and wide angle mirrors electrically heated. Cab width 2130 mm.; Green tinted glass; Electrically adjustable mirrors; Mirror brackets, body 2.50-2.60 m; Front view mirror.

Optional

02576 Extended Day Cab	07343 Kerb view window co-driver door
02106 Sleeper Cab	00915 Side no glass / rear single glass
01173 Cab suspension mechanical	09101 Green tinted glass, heated
01605 Cab suspension mechanical reinforced	03605 Mirror brackets, body 2.10-2.29 m
09983 Fog lights	09282 Mirror brackets, body 2.30-2.40 m
09984 Fog lights and cornering lights	09283 Mirror brackets, body 2.40-2.50 m

AERODYNAMICS

Optional

09287 Side collars prepared	07112 Side collars long (set)
------------------------------------	--------------------------------------

COLOURS

; Head lamp panel and bumper: Stone Grey; Chassis colour grey..

Optional

06485 Head lamp panel and bumper: cab colour	16153 Cab and chassis colours
---	--------------------------------------

CAB INTERIOR

Left-hand drive (LHD); Mechanically adjustable steering column; Driver seat: air suspended; Co-driver seat: fixed velour; Storage box on engine tunnel.

Optional

01847 Right-hand drive (RHD)	04346 Lower bunk, normal level
09271 Steering wheel, leather, colour black	02213 Air conditioning
03516 Pneumatically adjustable steering column	03703 Auxiliary cab heater Air Top 2000
00967 Seat belts red	04246 Roof hatch, manual control
16158 Seat types	04258 Roof hatch, electric control

COMMUNICATION AND DRIVING MANAGEMENT

FMS connector, prepared; Tachograph digital, Stoneridge 1C version G2V2; Adaptive Cruise Control with FCW and AEBS-3.

Optional

16155 Audio equipment, makes and types

SAFETY AND SECURITY

Lane Departure Warning System; Vehicle Stability Control (VSC); Basic engine immobiliser system.

Optional

08631 Air bag (driver) and 2 seat belt tensioners	06634 Immobiliser 5 minutes and alarm (SCM BV03-B2)
01725 Reverse warning	06635 Immobiliser 15 minutes and alarm (SCM BV03-B3)
07414 Reverse warning with self-adjusting volume	16156 EC-ADR packages
06633 Immobiliser 5 minutes (SCM BV03-B1)	

SUSPENSION AND AXLES

Front: 4.50 t, parabolic, F48; Rear: 8.50 t, parabolic, SR8.22.

Optional

01372 Rear springs air	00369 Rear springs parabolic, asymmetric
-------------------------------	---

WHEELS AND TYRES

Front axle(s): 245/70R17.5; Driven rear axle(s): 245/70R17.5; Wheel protection rings silvergrey.

Optional

06764 Wheel protection rings black	16152 Tyre makes and types
---	-----------------------------------

DRIVELINE

Engine PX-5, 4 cylinder diesel engine, 4.5 litres. Output 139 kW (189 hp) at 2300 rpm. Max. torque 745 Nm at 1200-1700 rpm.; Exhaust emission Euro 6; Engine idle shutdown, 5 minutes; Manual gearbox, 6 speeds; Gearbox ratio 6.58-0.78; Rear axle ratio 3.31.

Optional

07667 Automatic gearbox PowerLine, 8-speed	09888 Automatic gearbox, 5 speeds
---	--

BRAKE SYSTEM

Exhaust brake.

CHASSIS

Wheelbase 4.30 m / rear overhang 2.18 m; Side member height 210 mm; EAS unit right, discharge right rearward; Plastic fuel tank 110 l; Tank for AdBlue® 30 l, right-hand side chassis; Spray suppression.

Optional

02011 Spare wheel carrier in rear overhang	03323 Rear light with LEDs
07071 Spare wheel carrier right-hand side	

DRAWBAR AND TRAILER EQUIPMENT

Closing member.

Optional

04661 D-value cross member D= 8.5
--

BODIES AND PREPARATIONS FOR BODYING

No BodyBuilder Module (BBM); Application connector chassis; Standard body attachment hole pattern.

Optional

09952 BodyBuilder Module (BBM) full	01503 Side marker lights
02597 Application connector for tail lift control	07487 Body attachment BAM 1, loose consoles supply
02950 Application connector for hydraulic platform	07488 Body attachment BAM 3, loose consoles supply
09240 Application connector for refuse collector	

POWER TAKE-OFF (PTO)

Optional

06624 Indirect front engine PTO	16148 PTO types and positions
06785 Front engine PTO, generator preparation 22.5 kW	

24V POWER SUPPLY

Alternator 80 A, batteries 2x 125 Ah..

Optional

01897 Alternator 100 A **08797** Batteries 2x175Ah

GVM AND GCM

Chassis weight related technical GVM max 12000 kg; Driveline related technical GCM equal to GVM.

Optional

00054 Driveline related max GCM 18000 kg **08629** Driveline related max GCM 22000 kg
00728 Driveline related max GCM 20000 kg **03700** Driveline related technical GCM = GVM+3500 kg

APPLICATION CONDITIONS

Moisture separator, unheated; Air intake low.

Optional

02270 Cold climate **09960** Air intake on the cab roof
04767 Moisture separator, heated **04987** Radiator flyscreen
04482 Air intake high behind cab

VEHICLE DELIVERY

Standard toolkit.



Go to [DAF.com](https://www.daf.com) to configure your own perfect DAF.

LF 190

FA 4X2 Rigid, 12t

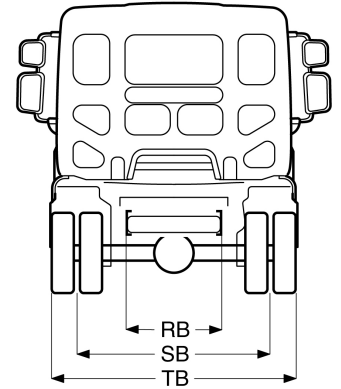
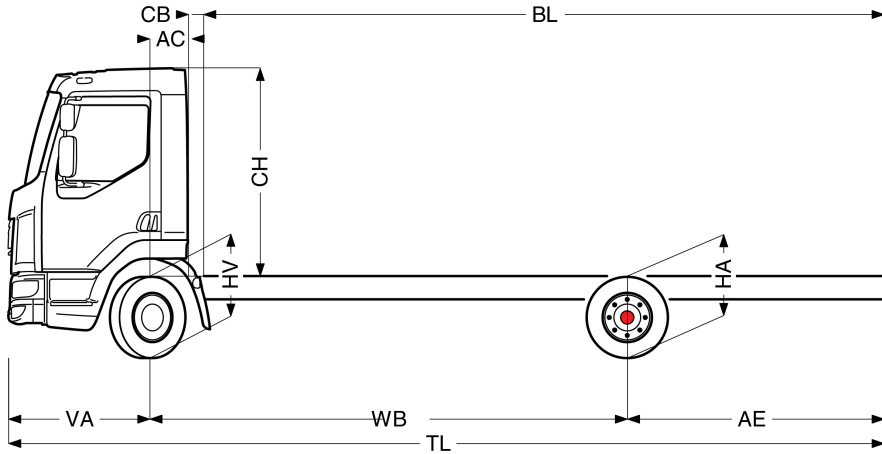

	Wheelbase - AE		Unladen weight ¹⁾			Gross Carrying Capacity			Variable dimensions									
	WB	AE ⁵⁾	Front	Rear	Total	Front	Rear	Total	AC	CB ⁶⁾	CH ⁷⁾	BL ⁸⁾	BL	TL	HA ⁹⁾	HA ¹⁰⁾	TK ¹¹⁾	TW ¹²⁾
DAY CAB	3,15	1,73	2454	1002	3456	2026	7478	8544	0,33	0,12	1,84	3,89	4,62	6,16	0,98	0,89	11,41	12,66
	3,55	1,98	2456	1032	3488	2024	7448	8512	0,33	0,12	1,84	4,50	5,32	6,81	0,98	0,89	12,44	13,72
	3,90	2,23	2455	1054	3509	2025	7426	8491	0,33	0,12	1,84	5,03	5,94	7,41	0,98	0,89	13,35	14,64
	4,30	2,18	2469	1065	3533	2011	7415	8467	0,33	0,12	1,84	5,64	6,65	7,76	0,98	0,90	14,39	15,70
	4,65	2,75	2460	1105	3565	2020	7375	8435	0,33	0,12	1,84	6,16	7,25	8,68	0,98	0,89	15,30	16,62
	5,00	2,46	2484	1101	3585	1996	7379	8415	0,33	0,12	1,84	6,71	7,89	8,74	0,98	0,91	16,21	17,55
	5,40	2,43	2497	1112	3609	1983	7368	8391	0,33	0,12	1,84	7,33	8,60	9,11	0,98	0,92	17,26	18,60
	5,70	2,41	2509	1123	3632	1971	7357	8368	0,33	0,12	1,84	7,79	9,14	9,39	0,98	0,93	18,05	19,40
	6,10	2,65	2514	1145	3659	1966	7335	8341	0,33	0,12	1,84	8,41	9,85	10,03	0,98	0,93	19,09	20,45
	6,40	2,80	2521	1164	3685	1959	7316	8315	0,33	0,12	1,84	8,86	10,39	10,48	0,98	0,93	19,88	21,25
6,70	3,00	2527	1186	3712	1953	7294	8288	0,33	0,12	1,84	9,31	10,93	10,98	0,98	0,92	20,67	22,04	
SLEEPER CAB	WB	AE ⁵⁾	Front	Rear	Total	Front	Rear	Total	AC	CB ⁶⁾	CH ⁷⁾	BL ⁸⁾	BL	TL	HA ⁹⁾	HA ¹⁰⁾	TK ¹¹⁾	TW ¹²⁾
	3,55	1,98	2561	1050	3612	1919	7430	8389	0,73	0,07	1,87	3,86	4,70	6,81	0,98	0,87	12,44	13,72
	3,90	2,23	2562	1070	3633	1918	7410	8367	0,73	0,07	1,87	4,40	5,32	7,41	0,98	0,87	13,35	14,64
	4,30	2,18	2577	1080	3657	1903	7400	8343	0,73	0,07	1,87	5,03	6,04	7,76	0,98	0,89	14,39	15,70
	4,65	2,75	2570	1119	3688	1910	7361	8312	0,73	0,07	1,87	5,55	6,65	8,68	0,98	0,87	15,30	16,62
	5,00	2,46	2594	1114	3708	1886	7366	8292	0,73	0,07	1,87	6,11	7,31	8,74	0,98	0,90	16,21	17,55
	5,40	2,43	2608	1124	3733	1872	7356	8267	0,73	0,07	1,87	6,74	8,02	9,11	0,98	0,91	17,26	18,60
	5,70	2,41	2621	1134	3756	1859	7346	8244	0,73	0,07	1,87	7,21	8,58	9,39	0,98	0,92	18,05	19,40
6,10	2,65	2627	1155	3783	1853	7325	8217	0,73	0,07	1,87	7,83	9,29	10,03	0,98	0,92	19,09	20,45	
6,40	2,80	2634	1174	3808	1846	7306	8192	0,73	0,07	1,87	8,29	9,84	10,48	0,98	0,92	19,88	21,25	
6,70	3,00	2640	1195	3836	1840	7285	8164	0,73	0,07	1,87	8,75	10,39	10,98	0,98	0,92	20,67	22,04	

OTHER DIMENSIONS VA: 1,28 HV¹³⁾: 0,93 HV¹⁴⁾: 0,85 RB: 0,86 SB: 1,74 TB¹⁵⁾: 2,32

- GVM in conformity with registration documents.
- GCM in conformity with registration documents.
- Axle load with standard tyre size.
- Chassis and cab weight calculated with: Standard specification items only with 0 litres of fuel, 0 litres of AdBlue® and driver of 75 kg, tolerance ± 3%. Changing of the specification can have major impact on vehicle weight.
- Other AE dimensions may be available for shown WB. Modify rear overhang to the calculated body length.
- CB is based on standard air intake and/or exhaust.
- Cab height is measured from frame member to closed cabin roof hatch.
- Calculate customer specific body length with TOPEC. Body lengths shown based on evenly distributed load at max axle load.
- Unladen height at centre of driven axle(s).
- Laden height at centre of driven axle(s).
- TK = turning circle between kerbs.
- TW = turning circle between walls.
- Unladen height at centre of front axle(s).
- Laden height at centre of front axle(s).
- TB is overall width at rear. (At centre of front axle 255).

Depending on the vehicle configuration a specific option may not be possible. The availability and specification of this vehicle may differ per country. For further information please contact the DAF organisation. Pictures and technical illustrations are not binding in detail and can differ from the standard specification. Subject to modification without prior notice.