

Specification sheet

CF 230

FA 4X2 Rigid



ENGINES

- CF 230 PX-7 (172 kW / 234 hp)
- CF 260 PX-7 (194 kW / 264 hp)
- CF 290 PX-7 (217 kW / 295 hp)
- CF 320 PX-7 (239 kW / 325 hp)

GVM¹⁾

- 18000 kg
- Max. front 7500 kg
- Max. rear 11500 kg

GCM²⁾

- 19000 kg

097F6606AAAA - 202345D - 21-08-2023

TurboTrucks Bulgaria Ltd, www.turbotrucks.bg

CAB EXTERIOR

Day Cab with galvanised steel bumper, tinted glass and electric window openers. Main mirrors and wide angle mirrors electrically heated. Cab width 2300 mm.; LED daytime running lights; Electrically adjustable mirrors; Front view mirror.

Optional

02106 Sleeper Cab	06593 Skylights
01137 Space Cab	06628 One hazard beacon light at co-driver side
01174 External sun visor green translucent	06627 One hazard beacon light at driver side
09983 Fog lights	06629 Two hazard beacon lights
09984 Fog lights and cornering lights	

AERODYNAMICS

Optional

04906 Side collars

COLOURS

Cab colour H3279 Brilliant White; Head lamp panel and bumper: Brilliant White; Chassis colour grey..

Optional

06485 Head lamp panel and bumper: cab colour	07245 Mirror covers Brilliant White
09933 Head lamp panel and bumper: Stone Grey	04198 Mirror covers in cab colour
06442 Mirror covers grey	16153 Cab and chassis colours

CAB INTERIOR

Driver seat: Comfort Air; Co-driver seat: basic; Automatic Temperature Control and airco; Pollen filter; Roof hatch glass, manual control.

Optional

09271 Steering wheel, leather, colour black	07741 Co-driver seat: Comfort Air
07240 Steering wheel, leather, Exclusive	07743 Co-driver seat: Luxury Air
07152 Cab interior trim colour Exclusive	07746 Co-driver seat: Super Air
07592 Cab interior decoration Argenta	07748 Co-driver seat: Xtra Leather Air
07591 Cab interior decoration Rustica	00967 Seat belts red
07733 Driver seat: Luxury Air	02117 Third seat
07736 Driver seat: Super Air	06539 Refrigerator
07737 Driver seat: Xtra Leather Air	06599 Auxiliary cab heater (air)

COMMUNICATION AND DRIVING MANAGEMENT

Tachograph digital, Stoneridge 1C version G2V2; Speed limiter setting 85 km/h absolute; Antennas: radio, 2x cellular, GNSS; Adaptive Cruise Control with FCW and AEBS-3.

Optional

16155 Audio equipment, makes and types

SAFETY AND SECURITY

Vehicle Stability Control (VSC); Basic engine immobiliser system.

Optional

01725 Reverse warning	16156 EC-ADR packages
07414 Reverse warning with self-adjusting volume	

SUSPENSION AND AXLES

Front axle load 7.50 t; Rear: 11.50 t, air suspension, SR1132.

Optional

01800 Rear axle SR1344	01778 Rear axle load 13.00 t
01603 Rear springs parabolic	

WHEELS AND TYRES

Front axle(s): 315/70R22.5; Driven rear axle(s): 315/70R22.5; Disc wheels steel, silvergrey; Wheel protection rings silvergrey.

Optional

16152 Tyre makes and types

DRIVELINE

Engine PX-7, 6 cylinder diesel engine, 6.7 litres. Output 172 kW (234 hp) at 2300 rpm. Max. torque 900 Nm at 1000-1700 rpm.; Exhaust emission Euro 6; Engine idle shutdown, 5 minutes; Manual gearbox, 6 speeds; Gearbox ratio 6.75-0.78; Rear axle ratio 4.56.

Optional

04393 Manual gearbox, 9 speeds	04500 AS Tronic gearbox, 12 speeds
08834 AS Tronic gearbox, 6 speeds	02843 Mechanical differential lock

CHASSIS

Wheelbase 5.10 m / rear overhang 2.30 m; Side member height 270 mm; Plastic fuel tank 200 l; Tank for AdBlue® 25 l, right-hand side chassis; Front underrun protection (FUP); Spray suppression.

Optional

16157 Fuel tanks, material and sizes	07071 Spare wheel carrier right-hand side
---	--

DRAWBAR AND TRAILER EQUIPMENT

Closing member.

Optional

04661 D-value cross member D= 8.5	01948 D-value cross member D=10
--	--

BODIES AND PREPARATIONS FOR BODYING

Application connector on the cab front.

POWER TAKE-OFF (PTO)

Optional

16148 PTO types and positions

24V POWER SUPPLY

Alternator 80 A, batteries 2x 125 Ah..

Optional

01897 Alternator 100 A	08797 Batteries 2x175Ah
-------------------------------	--------------------------------

GVM AND GCM

Chassis weight related technical GVM max 19000 kg; Driveline related max GCM 19000 kg.

Optional

- | | |
|---|---|
| 00064 Driveline related max GCM 22500 kg | 00620 Driveline related max GCM 28000 kg |
| 02658 Driveline related max GCM 26000 kg | 03027 Driveline related max GCM 32000 kg class 3 |

APPLICATION CONDITIONS

Moisture separator, unheated; Air intake on the cab roof.

Optional

- | | |
|---|---------------------------------|
| 02270 Cold climate | 04987 Radiator flyscreen |
| 09961 Cyclonic air intake behind the cab | |



Go to [DAF.com](https://www.daf.com) to configure your own perfect DAF.

CF 230

FA 4X2 Rigid

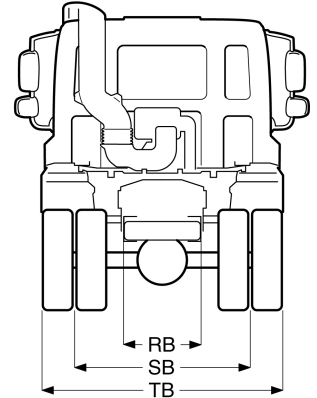
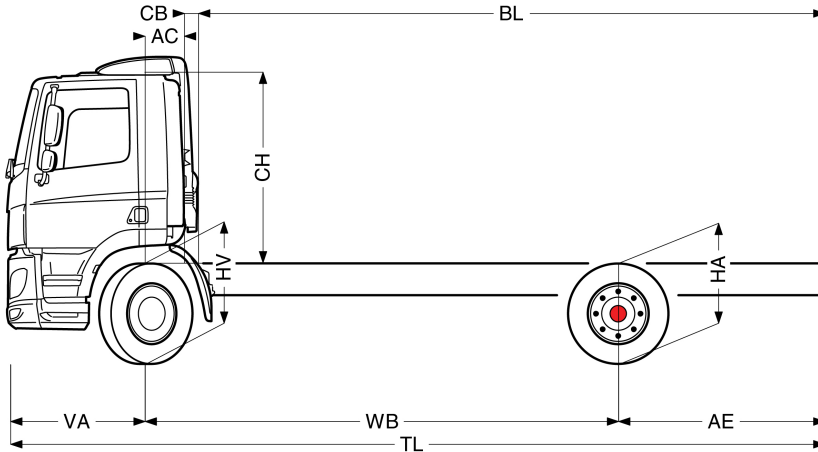

	Wheelbase - AE		Unladen weight ¹⁾			Gross Carrying Capacity			Variable dimensions									
	WB	AE ⁵⁾	Front	Rear	Total	Front	Rear	Total	AC	CB ⁶⁾	CH ⁷⁾	BL ⁸⁾	BL	TL	HA ⁹⁾	HA ¹⁰⁾	TK ¹¹⁾	TW ¹²⁾
DAY CAB	4,00	1,70	4107	2330	6437	3393	9170	11563	0,39	0,18	1,98	4,70	4,70	7,07	1,00	0,97	14,46	15,86
	4,15	1,85	4110	2342	6451	3390	9158	11549	0,39	0,18	1,98	4,92	4,92	7,37	1,00	0,97	14,87	16,28
	4,45	2,00	4127	2360	6488	3373	9140	11512	0,39	0,18	1,98	5,37	5,37	7,82	1,00	0,97	15,69	17,11
	4,75	2,00	4143	2360	6503	3357	9140	11497	0,39	0,18	1,98	5,82	5,82	8,12	1,00	0,97	16,51	17,94
	4,90	2,15	4145	2372	6518	3355	9128	11482	0,39	0,18	1,98	6,03	6,03	8,42	1,00	0,97	16,92	18,36
	5,10	2,30	4160	2396	6556	3340	9104	11444	0,39	0,18	1,98	6,33	6,33	8,77	1,00	0,97	17,47	18,91
	5,40	2,40	4191	2435	6626	3309	9065	11374	0,39	0,18	1,98	6,77	6,77	9,17	1,00	0,97	18,30	19,74
	5,70	2,65	4204	2469	6673	3296	9031	11327	0,39	0,18	1,98	7,21	7,21	9,72	1,00	0,97	19,12	20,58
	6,10	2,80	4219	2487	6706	3281	9013	11294	0,39	0,18	1,98	7,80	7,80	10,27	1,00	0,97	20,22	21,69
	6,60	2,85	4250	2506	6756	3250	8994	11244	0,39	0,18	1,98	8,57	8,57	10,82	1,00	0,97	21,60	23,08
6,90	3,00	4272	2544	6816	3228	8956	11184	0,39	0,18	1,98	9,00	9,00	11,27	1,00	0,97	22,43	23,91	
7,30	3,30	4280	2576	6856	3220	8924	11144	0,39	0,18	1,98	9,60	9,60	11,97	1,00	0,97	23,54	25,02	
SLEEPER CAB	4,00	1,70	4152	2339	6491	3348	9161	11509	0,82	0,16	1,98	3,90	3,90	7,07	1,00	0,96	14,46	15,86
	4,15	1,85	4155	2350	6505	3345	9150	11495	0,82	0,16	1,98	4,12	4,12	7,37	1,00	0,96	14,87	16,28
	4,45	2,00	4174	2368	6542	3326	9132	11458	0,82	0,16	1,98	4,57	4,57	7,82	1,00	0,96	15,69	17,11
	4,75	2,00	4190	2368	6557	3310	9132	11443	0,82	0,16	1,98	5,01	5,01	8,12	1,00	0,96	16,51	17,94
	4,90	2,15	4192	2379	6572	3308	9121	11428	0,82	0,16	1,98	5,24	5,24	8,42	1,00	0,96	16,92	18,36
	5,10	2,30	4207	2402	6610	3293	9098	11390	0,82	0,16	1,98	5,53	5,53	8,77	1,00	0,96	17,47	18,91
	5,40	2,40	4239	2441	6680	3261	9059	11320	0,82	0,16	1,98	5,98	5,98	9,17	1,00	0,97	18,30	19,74
	5,70	2,65	4252	2475	6727	3248	9025	11273	0,82	0,16	1,98	6,43	6,43	9,72	1,00	0,96	19,12	20,58
	6,10	2,80	4267	2493	6760	3233	9007	11240	0,82	0,16	1,98	7,02	7,02	10,27	1,00	0,97	20,22	21,69
	6,60	2,85	4299	2511	6810	3201	8989	11190	0,82	0,16	1,98	7,78	7,78	10,82	1,00	0,97	21,60	23,08
6,90	3,00	4321	2549	6870	3179	8951	11130	0,82	0,16	1,98	8,23	8,23	11,27	1,00	0,97	22,43	23,91	
7,30	3,30	4329	2581	6910	3171	8919	11090	0,82	0,16	1,98	8,82	8,82	11,97	1,00	0,97	23,54	25,02	
SPACE CAB	4,00	1,70	4265	2340	6604	3235	9160	11396	0,82	0,16	2,66	3,95	3,95	7,07	1,00	0,96	14,46	15,86
	4,15	1,85	4268	2351	6618	3232	9149	11382	0,82	0,16	2,66	4,17	4,17	7,37	1,00	0,96	14,87	16,28
	4,45	2,00	4286	2369	6655	3214	9131	11345	0,82	0,16	2,66	4,62	4,62	7,82	1,00	0,96	15,69	17,11
	4,75	2,00	4303	2368	6671	3197	9132	11329	0,82	0,16	2,66	5,08	5,08	8,12	1,00	0,97	16,51	17,94
	4,90	2,15	4305	2380	6685	3195	9120	11315	0,82	0,16	2,66	5,30	5,30	8,42	1,00	0,97	16,92	18,36
	5,10	2,30	4320	2403	6723	3180	9097	11277	0,82	0,16	2,66	5,60	5,60	8,77	1,00	0,96	17,47	18,91
	5,40	2,40	4352	2442	6793	3148	9058	11207	0,82	0,16	2,66	6,06	6,06	9,17	1,00	0,97	18,30	19,74
	5,70	2,65	4365	2476	6840	3135	9024	11160	0,82	0,16	2,66	6,51	6,51	9,72	1,00	0,97	19,12	20,58
	6,10	2,80	4380	2493	6873	3120	9007	11127	0,82	0,16	2,66	7,10	7,10	10,27	1,00	0,97	20,22	21,69
	6,60	2,85	4411	2512	6923	3089	8988	11077	0,82	0,16	2,66	7,87	7,87	10,82	1,00	0,97	21,60	23,08
6,90	3,00	4434	2550	6983	3066	8950	11017	0,82	0,16	2,66	8,32	8,32	11,27	1,00	0,97	22,43	23,91	
7,30	3,30	4442	2581	7023	3058	8919	10977	0,82	0,16	2,66	8,92	8,92	11,97	1,00	0,97	23,54	25,02	

OTHER DIMENSIONS VA: 1,37 HV¹³⁾: 1,03 HV¹⁴⁾: 1,01 RB: 0,79 SB: 1,83 TB¹⁵⁾: 2,47

- GVM in conformity with registration documents.
- GCM in conformity with registration documents.
- Axle load with standard tyre size.
- Chassis and cab weight calculated with: Standard specification items only with 180 litres of fuel, 23 litres of AdBlue® and driver of 75 kg, tolerance ± 3%. Changing of the specification can have major impact on vehicle weight.
- Other AE dimensions may be available for shown WB. Modify rear overhang to the calculated body length.
- CB is based on standard air intake and/or exhaust.
- Cab height is measured from frame member to closed cabin roof hatch.
- Calculate customer specific body length with TOPEC. Body lengths shown based on evenly distributed load at max axle load.
- Unladen height at centre of driven axle(s).
- Laden height at centre of driven axle(s).
- TK = turning circle between kerbs.
- TW = turning circle between walls.
- Unladen height at centre of front axle(s).
- Laden height at centre of front axle(s).
- TB is overall width at rear. (At lower cab step 255).

Depending on the vehicle configuration a specific option may not be possible. The availability and specification of this vehicle may differ per country. For further information please contact the DAF organisation. Pictures and technical illustrations are not binding in detail and can differ from the standard specification. Subject to modification without prior notice.